

# PRORIL

50Hz

GOSPIN Series, the classical drainage pumps with strainer and rigid casting are engineered for various effluent pumping applications in commercial and industrial sectors.

Sewage Pump

## GOSPIN 215/315

Drainage Pump



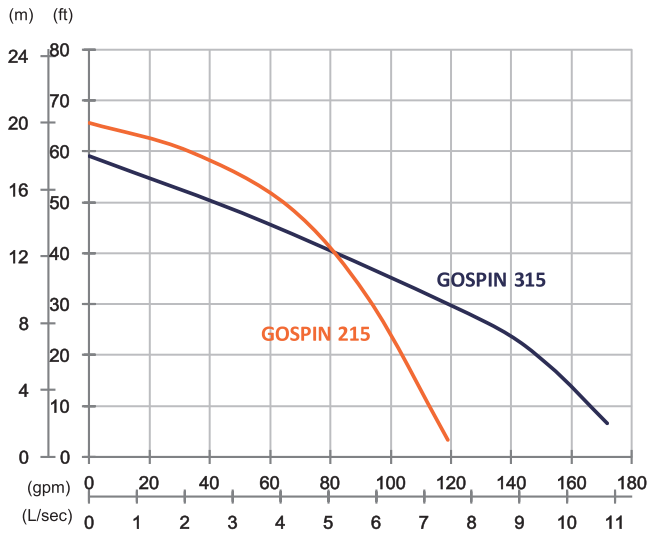

	GOSPIN 215	GOSPIN 315
<b>OUTPUT</b>	1.5 kW (2 HP)	1.5 kW (2 HP)
<b>OUTLET</b>	2" (50 mm)	3" (80 mm)
<b>SOLID PASSAGE</b>	7 mm	7 mm
<b>Weight</b>	23 kg	23 kg
<b>HEAD</b>	Rated: 15 m Max: 20 m	Rated: 8 m Max: 18 m
<b>FLOW</b>	Rated: 4.2 L/s Max: 7.5 L/s	Rated: 8.3 L/s Max: 10.8 L/s

<b>Pump Type</b>	Electric Submersible Pumps	
<b>Motor</b>	<b>Phase</b>	1-Phase, 3-Phase
	<b>Type</b>	Induction Motor
	<b>Poles</b>	2 Pole (2850 rpm)
	<b>Insulation</b>	Class F
	<b>Protector</b>	Circle Thermal Protector
	<b>Starter</b>	1-Phase · Capacitor-Run, 3-Phase · D.O.L.
<b>Lubricant</b>	Food Grade (ISO VG32)	
<b>Specs.</b>	<b>Impeller Type</b>	Semi-Open
	<b>Shaft Seal</b>	Double Mechanical Seal Silicon Carbide VS Ceramic/Carbon
	<b>Bearings</b>	C3 Shielded ball bearings
	<b>Cable</b>	H07RN-F 10 m or longer upon request
<b>Materials</b>	<b>Pump Casing</b>	Gray Iron
	<b>Impeller</b>	Gray Iron
	<b>Motor Frame</b>	Gray Iron
	<b>Motor Shaft</b>	Stainless Steel
	<b>Strainer</b>	Stainless Steel
<b>Max. Liquid Temperature</b>	40°C (104°F)	
<b>Max. Submersion Depth</b>	20 m (66 ft)	
<b>pH Range</b>	pH 5 - pH 8	
<b>Guide Rail</b>	GRL-02F (215)/GRL-03F (315)	

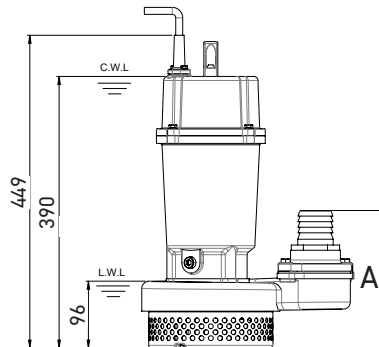
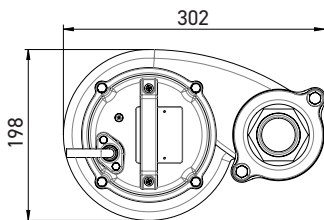

	A
GOSPIN 215	198
GOSPIN 315	234

unit : mm  
C.W.L : Continuous running water level  
L.W.L : Lowest running water level